

AMERICAN* METER

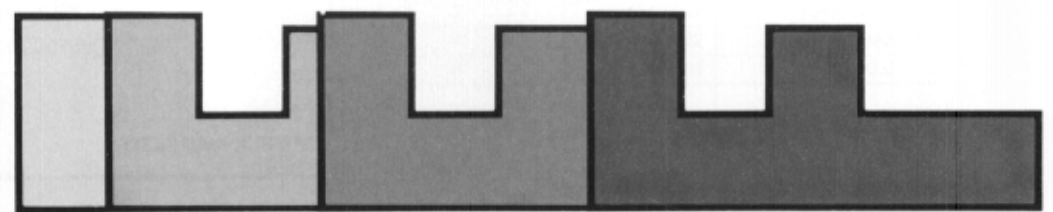

*Trademark of the AMERICAN METER CO.

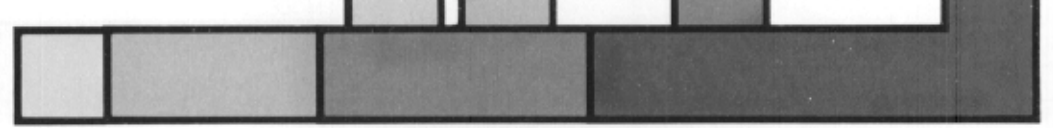
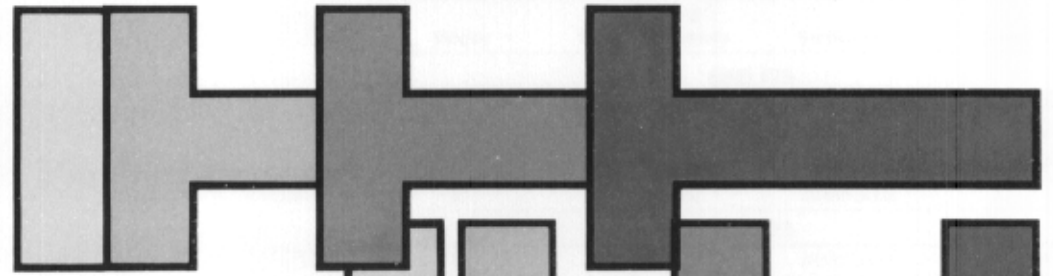
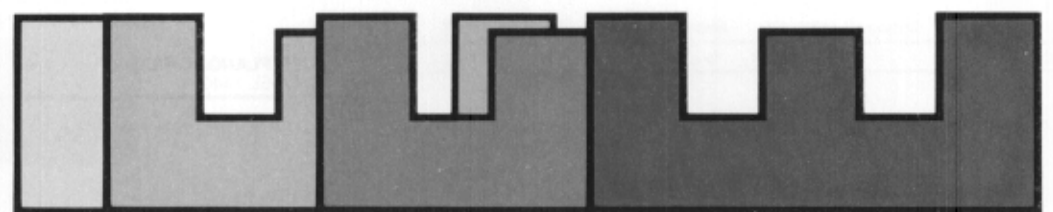
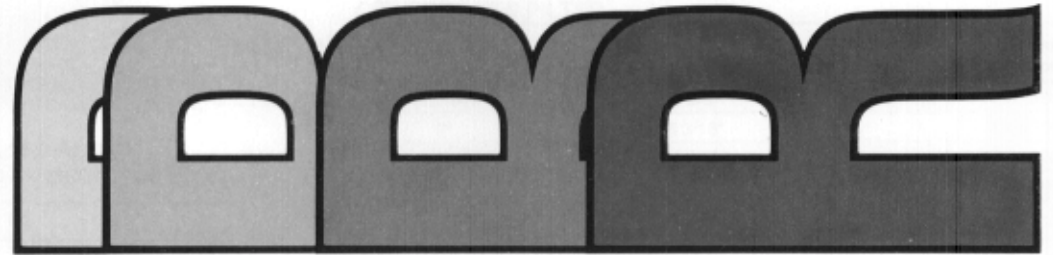
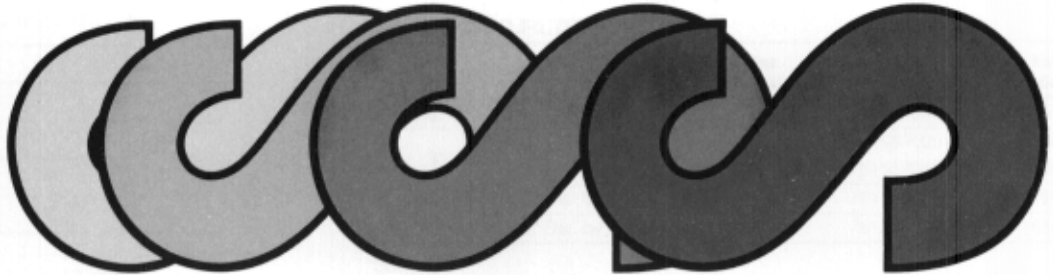

CFR FLANGED FILTER
MODEL 1440



CFR FLANGED FILTER
MODEL 275



CFR FLANGED FILTER
MODEL 175

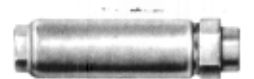

CFR SCREWED FILTER



CFR PILOT FILTER

American CFR gas filters, including flanged, screwed and pilot filters effectively remove dirt, pipe scale and other matter from gas lines in commercial and industrial applications. Filter elements are made of resin impregnated cellulose fiber so that moisture will not impair their effectiveness.

CFR flanged filters — recommended for large volume industrial and distribution service, are easy to install and maintain. The fabricated steel construction permits application with maximum working pressures from 175 psig to 1440 psig. The standard CFR flanged filter element will remove 25 micron particles; elements for removal of particles down to 10 microns are also available as a separate item. The filter element can be quickly replaced without disconnecting the piping. The CFR flanged high pressure filters (275#, 720# and 1440# W.P.) are manufactured to ASME Section VIII, Division 1 Specifications. U1A certification for these models is available.

CFR screwed filters — are generally used for residential and commercial service to protect water heaters, ranges, furnaces and other appliances. They also protect the regulator, meter and service piping from contaminants. Screwed filters are made of cast iron with maximum working pressures of 160 psig and will remove particles down to 5 microns.

CFR pilot filters — are generally used to protect pilot type regulators. They are of steel construction with maximum working pressure of 1000 psig and will remove particles down to 5 microns.

INSTALLATION and MAINTENANCE

INSTALLATION

CAUTION: In designing the installation, enough room must be left to remove and replace filter elements.

MAINTENANCE

WARNING: Filters must be depressurized before any maintenance procedures are performed.

All flanged filters contain one upstream and one downstream 1/4" NPT pipe taps for differential pressure measurement. A record of the differential pressure upon installation can be used for comparison at a later date. A change in differential pressure may indicate that a new element is needed.

The pressure to collapse the filter element is approximately 25 PSID. Good engineering practice suggests replacing the element at half or less of the collapse differential.

Filter elements for flanged filters are easily replaced by removing bolts and lifting off cover. On CFR 720 and 1440 models swivel attachment enables the heavier cover to be swung to either side. Manual lifting is not required on these two models of CFR filters. After cover is removed the element is simply and easily removed by lifting from the filter body. The element for CFR screwed type and pilot type filters are removed by disconnecting filter body from the line.

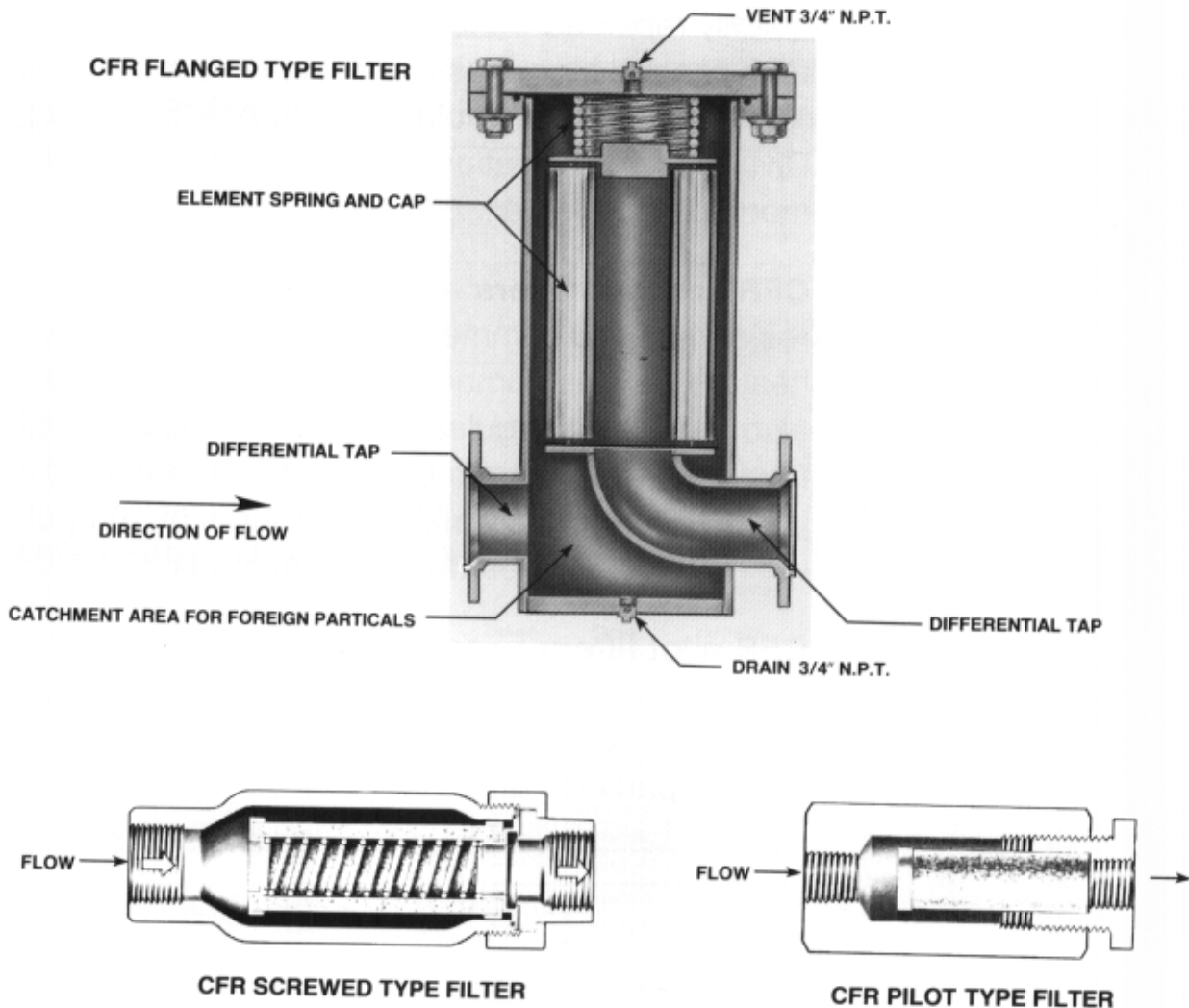

TYPE CFR FILTER TEST INSTALLATION for CAPACITY DATA

Capacity tables for flanged filters are based on 0.60 specific gravity gas* and are shown in SCFH and SCMH using a 25 micron filter element. The differential pressure is taken from line taps as shown in the drawing below and represents start up conditions only, using a new element. *The capacity tables are based on the use of line pressure taps so as to include the pressure drop created by the filter body.*

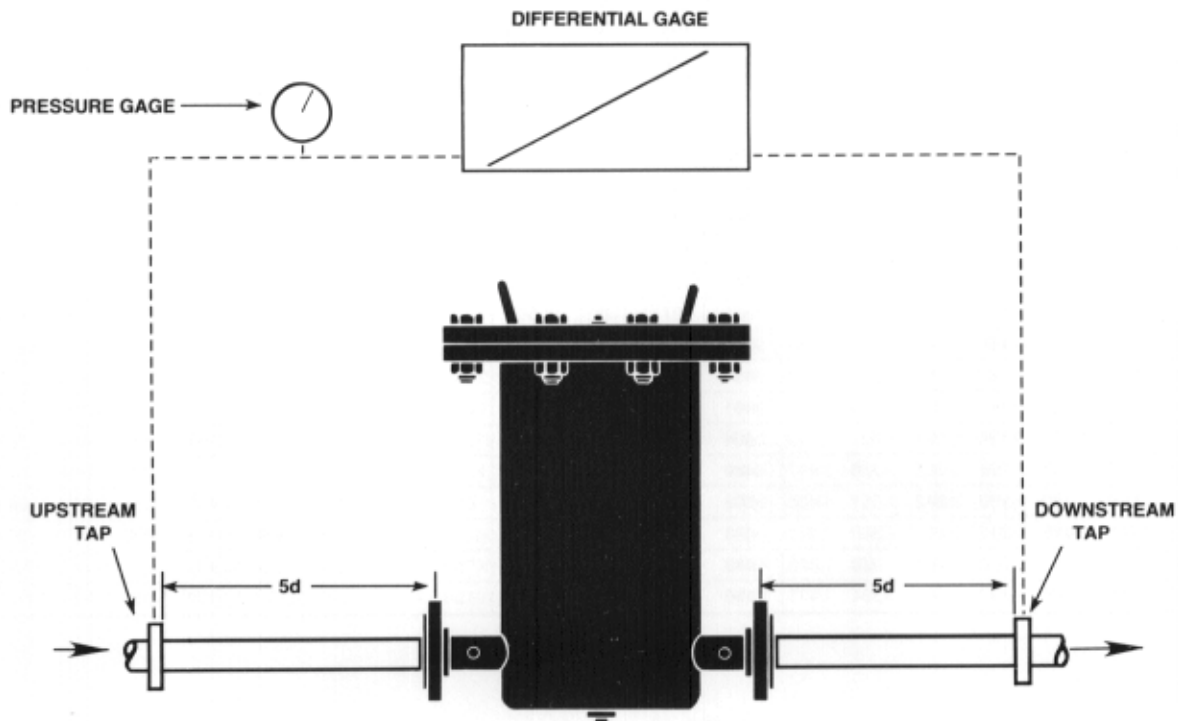

CFR FLANGED FILTER 1440
with cover swivel attachment
to simplify removal of filter element.

* For other specific gravities, apply the following multipliers:

Specific Gravity	Multiply By
0.45	1.15
0.60	1.00
0.64	0.97
1.00	0.77
1.12	0.73
1.50	0.63

TABLE 1

CAPACITY TABLES 0.6 SPECIFIC GRAVITY*

The differential pressure is taken from line taps shown in the drawing on page 5 and represents startup conditions only, using a new element.

2" CFR FILTER FLANGED (000) SCFH

3" CFR FLANGED FILTER (000) SCFH

INLET PRESSURE PSIG	DIFFERENTIAL PRESSURE (LINE TAPS)									
	0.5" WC	1" WC	5" WC	10" WC	20" WC	1 PSI	2 PSI	3 PSI	4 PSI	5 PSI
.25	3	5	11							
2	3	5	11	16	24	28				
5	4	5	12	18	26	31	45	55	65	
10	4	6	14	20	29	35	50	62	72	82
20	5	7	16	24	34	41	59	74	86	97
30	5	8	19	27	39	46	67	84	97	110
40	6	9	21	30	43	51	74	92	108	121
50	7	9	22	32	47	56	81	101	117	132
75	8	11	26	38	55	66	95	118	138	155
100	9	13	30	43	63	74	108	134	156	176
125	10	14	33	48	69	82	119	148	172	194
150	10	15	36	52	75	89	129	160	187	211
200	12	17	41	59	86	102	147	183	213	241
250	13	19	45	66	95	113	164	203	237	267
300	14	21	49	72	104	123	178	221	258	291
400	17	24	57	82	119	141	205	254	297	334
500	18	27	63	91	132	158	228	283	331	372
600	20	29	69	100	145	172	249	310	361	407
700	22	32	74	108	156	186	269	334	390	439
800	23	34	79	115	167	198	287	357	416	469
900	25	36	84	122	177	210	304	378	441	496
1000	26	38	89	128	186	221	321	398	464	523
1100	27	39	93	135	195	232	336	417	486	548
1200	28	41	97	140	203	242	351	435	508	572
1300	30	43	101	146	212	252	365	453	528	595
1400	31	44	105	152	220	261	378	470	548	617
1440	31	45	106	154	223	265	384	477	556	626

INLET PRESSURE PSIG	DIFFERENTIAL PRESSURE (LINE TAPS)									
	0.5" WC	1" WC	5" WC	10" WC	20" WC	1 PSI	2 PSI	3 PSI	4 PSI	5 PSI
.25	6	9	21							
2	6	9	22	32	47	56				
5	7	10	24	35	51	61	88	110	128	
10	8	11	27	39	57	68	99	123	144	162
20	9	13	32	46	68	81	117	146	170	192
30	10	15	36	53	77	91	133	166	193	218
40	12	17	40	58	85	101	147	183	214	241
50	13	18	44	63	92	110	160	199	233	263
75	15	21	51	75	109	129	188	235	274	309
100	17	24	58	84	123	146	213	265	310	350
125	18	27	64	93	135	162	235	293	342	386
150	20	29	70	101	147	175	255	318	371	419
200	23	33	79	115	168	200	291	363	424	478
250	25	37	88	128	186	222	324	403	471	531
300	28	40	96	140	203	243	353	439	513	579
400	32	46	110	160	233	278	405	504	589	665
500	35	51	123	179	260	310	451	562	657	741
600	39	56	134	195	284	339	493	614	717	810
700	42	61	145	211	306	366	532	662	774	873
800	44	65	155	225	327	390	568	707	826	932
900	47	69	164	238	347	414	602	749	875	987
1000	50	72	173	251	365	436	634	789	922	1040
1100	52	76	181	263	383	456	664	827	966	1090
1200	54	79	189	275	400	477	693	863	1009	1138
1300	57	82	196	286	416	496	721	898	1049	1184
1400	59	85	204	296	431	514	748	932	1088	1228
1440	59	87	207	301	437	521	759	945	1104	1245

2" CFR FLANGED FILTER (00) SCMH

3" CFR FLANGED FILTER (00) SCMH

INLET PRESSURE BARS	DIFFERENTIAL PRESSURE (LINE TAPS)									
	1 MB	2 MB	5 MB	10 MB	20 MB	50 MB	100 MB	150 MB	250 MB	350 MB
.5	1	2	3	5	8	11	14	18	22	
1	1	2	3	4	5	9	13	16	21	25
2	1	2	3	5	7	11	16	20	26	31
3	2	2	4	5	8	13	18	21	30	36
4	2	3	4	6	9	14	20	25	33	40
5	2	3	5	7	9	15	22	28	37	44
10	3	4	6	9	13	21	30	38	49	59
15	3	5	7	11	15	25	37	45	60	71
20	4	5	8	12	18	29	42	52	68	82
25	4	6	9	14	20	32	47	58	76	91
30	4	6	10	15	22	35	51	63	83	99
40	5	7	12	17	25	40	59	73	95	114
50	6	8	13	19	28	45	65	81	106	127
60	6	9	14	21	30	49	71	89	116	139
70	7	10	16	23	33	53	77	96	126	150
80	7	10	17	24	35	57	82	102	134	161
90	7	11	18	25	37	60	87	108	142	170
100	8	12	19	27	39	63	92	114	150	179

INLET PRESSURE BARS	DIFFERENTIAL PRESSURE (LINE TAPS)									
	1 MB	2 MB	5 MB	10 MB	20 MB	50 MB	100 MB	150 MB	250 MB	350 MB
.5	2	3	4	6	9	15	22	28	36	44
1	2	3	5	7	11	18	26	32	42	50
2	3	4	6	9	13	22	31	39	51	62
3	3	4	7	10	15	25	36	45	59	71
4	3	5	8	12	17	28	40	50	66	80
5	4	5	9	13	19	30	44	55	73	87
10	5	7	12	17	25	41	60	75	98	118
15	6	9	14	21	30	50	72	90	118	142
20	7	10	16	24	35	57	83	103	136	163
25	8	11	18	26	39	63	92	115	151	181
30	8	12	20	29	42	69	100	125	165	198
40	10	14	23	33	48	79	115	144	190	227
50	11	16	25	37	54	89	129	160	211	254
60	12	17	28	41	59	97	141	175	231	277
70	13	18	30	44	64	104	152	189	249	296
80	13	20	32	47	68	112	162	202	266	320
90	14	21	34	50	72	118	172	214	282	339
100	15	22	36	52	76	125	181	226	297	357

1 Bar = 100 kPa 1 MB (Millibar) = 0.1 kPa

1 Bar = 100 kPa 1 MB (Millibar) = 0.1 kPa

CAPACITY TABLES 0.6 SPECIFIC GRAVITY*

The differential pressure is taken from line taps shown in the drawing on page 5 and represents startup conditions only, using a new element.

4" CFR FLANGED FILTER (000) SCFH

INLET PRESSURE PSIG	DIFFERENTIAL PRESSURE (LINE TAPS)									
	0.5" WC	1" WC	5" WC	10" WC	20" WC	1 PSI	2 PSI	3 PSI	4 PSI	5 PSI
.25	9	13	34							
2	9	14	36	55	82	99				
5	10	15	40	59	89	108	162	208	243	
10	11	17	44	67	100	121	182	230	273	311
20	14	20	52	79	118	143	215	273	323	368
30	15	23	60	89	134	163	244	310	367	418
40	17	26	66	99	149	180	270	343	406	462
50	19	28	72	108	162	196	294	373	441	503
75	22	33	84	127	190	230	346	439	520	592
100	25	37	95	143	215	261	391	496	587	670
125	27	41	105	158	237	288	432	548	648	739
150	30	44	114	172	258	312	469	595	704	802
200	34	51	131	196	294	356	535	679	804	916
250	38	56	145	218	327	396	594	754	892	1017
300	41	62	158	237	356	432	648	822	973	1109
400	47	71	181	273	409	495	744	944	1117	1273
500	52	79	202	304	456	552	829	1051	1244	1418
600	57	86	221	332	498	603	906	1149	1360	1550
700	62	93	238	358	537	650	977	1239	1466	1671
800	66	99	254	382	574	694	1043	1323	1566	1785
900	70	105	270	405	608	736	1105	1401	1659	1891
1000	74	110	284	426	640	775	1164	1476	1747	1992
1100	77	116	298	447	671	812	1220	1547	1831	2087
1200	80	121	311	466	700	848	1273	1615	1912	2179
1300	84	126	323	485	729	882	1325	1680	1989	2267
1400	87	130	335	503	756	915	1374	1743	2063	2352
1440	88	132	340	510	766	928	1393	1767	2092	2385

6" CFR FLANGED FILTER (000) SCFH

INLET PRESSURE PSIG	DIFFERENTIAL PRESSURE (LINE TAPS)									
	0.5" WC	1" WC	5" WC	10" WC	20" WC	1 PSI	2 PSI	3 PSI	4 PSI	5 PSI
.25	16	24	59							
2	17	25	63	93	138	166				
5	18	27	68	101	150	180	268	337	397	
10	21	30	76	113	168	202	300	377	445	505
20	24	36	90	134	199	239	355	447	527	598
30	28	41	103	152	225	272	403	508	598	679
40	31	45	113	168	250	301	446	562	662	751
50	33	49	123	183	272	327	485	611	720	817
75	39	58	145	216	320	385	571	719	847	962
100	44	66	164	244	362	435	646	813	958	1088
125	49	73	181	269	399	480	713	898	1057	1201
150	53	79	197	292	433	522	774	975	1148	1304
200	61	90	224	333	495	596	884	1113	1311	1488
250	67	100	250	370	549	661	981	1234	1456	1653
300	73	109	272	404	599	721	1070	1347	1587	1802
400	84	125	312	463	688	828	1228	1547	1822	2089
500	94	139	348	516	766	922	1368	1723	2030	2305
600	103	152	380	564	837	1008	1495	1883	2218	2519
700	111	164	410	608	903	1087	1612	2031	2392	2716
800	118	175	438	650	964	1160	1721	2168	2554	2899
900	125	186	464	688	1021	1229	1824	2297	2706	3072
1000	132	195	489	725	1075	1295	1921	2419	2850	3236
1100	138	205	512	760	1127	1357	2013	2536	2987	3392
1200	144	214	535	793	1177	1417	2102	2647	3116	3540
1300	150	223	556	825	1224	1474	2186	2754	3244	3683
1400	156	231	577	856	1270	1529	2268	2857	3365	3821
1440	158	234	585	868	1288	1550	2300	2897	3412	3874

4" CFR FLANGED FILTER (00) SCMH

INLET PRESSURE BARS	DIFFERENTIAL PRESSURE (LINE TAPS)									
	1 MB	2 MB	5 MB	10 MB	20 MB	50 MB	100 MB	150 MB	250 MB	350 MB
.5	3	4	7	10	16	27	40	51	69	84
1	3	5	8	12	18	31	46	59	79	97
2	4	6	10	15	22	38	57	72	97	118
3	4	7	11	17	25	44	65	83	112	136
4	5	7	13	19	28	49	73	93	125	152
5	5	8	14	21	31	53	80	101	137	167
10	7	11	19	28	42	72	108	137	185	226
15	9	13	23	34	51	87	131	166	223	272
20	10	15	26	39	58	100	150	190	256	312
25	11	17	29	43	65	111	166	211	285	347
30	12	18	31	47	71	121	182	230	311	379
40	14	21	36	54	81	139	209	265	358	436
50	16	23	40	60	91	155	233	296	399	486
60	17	26	44	66	99	170	255	323	436	531
70	18	28	47	71	107	183	275	349	471	573
80	20	30	51	76	114	196	294	373	503	612
90	21	31	54	81	121	207	311	395	533	649
100	22	33	57	85	128	218	328	416	561	684

1 Bar = 100 kPa 1 MB (Millibar) = 0.1 kPa

6" CFR FLANGED FILTER (00) SCMH

INLET PRESSURE BARS	DIFFERENTIAL PRESSURE (LINE TAPS)									
	1 MB	2 MB	5 MB	10 MB	20 MB	50 MB	100 MB	150 MB	250 MB	350 MB
.5	5	7	12	18	27	45	67	84	112	138
1	6	8	14	21	31	52	77	97	129	157
2	7	10	17	25	38	63	94	118	158	192
3	8	12	20	29	43	73	109	137	183	221
4	9	13	22	33	49	82	121	153	204	247
5	10	14	24	36	53	90	133	167	224	271
10	13	19	33	48	72	121	180	226	303	367
15	16	23	40	58	87	146	217	273	365	442
20	18	27	45	67	99	167	248	313	418	507
25	20	30	50	75	111	186	276	348	465	564
30	22	33	55	81	121	203	302	380	508	615
40	25	37	63	94	139	234	347	437	584	708
50	28	42	70	104	155	261	387	487	652	789
60	31	46	77	114	169	285	423	530	713	863
70	33	49	83	123	183	308	456	575	769	931
80	35	53	89	131	195	329	488	614	821	995
90	38	56	94	139	207	348	517	651	870	1054
100	40	59	99	147	218	367	544	686	917	1111

1 Bar = 100 kPa 1 MB (Millibar) = 0.1 kPa

*Note: For other specific gravities see Table 1, page 5

CAPACITY TABLES 0.6 SPECIFIC GRAVITY*

The differential pressure is taken from line taps shown in the drawing on page 5 and represents startup conditions only, using a new element.

CFR SCREWED FILTER SCFH

INLET PRESSURE PSIG	DIFFERENTIAL PRESSURE							
	1" WC	2" WC	5" WC	10" WC	20" WC	1 PSI	3 PSI	5 PSI
¾" NPT								
.25	462	652	—	—	—	—	—	—
1	543	668	1050	1480	—	—	—	—
5	605	792	1180	1670	2330	2730	—	—
10	675	883	1320	1870	2620	3070	—	—
20	794	1040	1640	2220	3120	3660	6140	—
30	897	1170	1850	2520	3550	4160	7040	—
50	1070	1400	2200	3040	4280	5030	8570	10900
75	1250	1640	2580	3600	5050	5930	10200	13000
100	1410	1840	2900	4050	5650	6710	11500	14800
125	1550	2030	3190	4450	6210	7420	12800	16300
150	1680	2200	3450	4820	6720	8060	13900	17800
160	1730	2260	3550	4960	6910	8200	14500	18300
1" NPT								
.25	543	766	—	—	—	—	—	—
1	640	785	1240	1740	—	—	—	—
5	713	933	1390	1960	2740	3200	—	—
10	795	1040	1560	2190	3080	3600	—	—
20	936	1230	1930	2600	3670	4300	7210	—
30	1060	1380	2180	2960	4170	4890	8280	—
50	1260	1650	2600	3570	5030	5900	10100	12800
75	1480	1930	3040	4240	5930	6970	11900	15200
100	1660	2170	3420	4770	6650	7890	13500	17300
125	1830	2390	3760	5240	7320	8710	15000	19200
150	1980	2590	4070	5680	7920	9470	16300	20900
160	2030	2660	4190	5840	8140	9900	17000	21500
1½" NPT								
.25	2600	3670	—	—	—	—	—	—
1	3040	3760	5920	8340	—	—	—	—
5	3390	4430	6640	9360	13100	15300	—	—
10	3770	4940	7440	10500	14700	17300	—	—
20	4440	5810	9150	12500	17600	20600	34600	—
30	5020	6560	10300	14200	20000	23400	39600	—
50	5990	7840	12300	17100	24100	28300	48200	61200
75	7010	9170	14400	20100	28400	33400	57100	72900
100	7890	10300	16200	22600	31600	37800	64800	82900
125	8670	11300	17800	24900	34700	41700	71700	91900
150	9380	12300	19300	26900	37600	45300	78000	100000
160	9650	12600	19900	27700	38700	46000	81000	102000
2" NPT								
.25	3350	4230	—	—	—	—	—	—
1	3910	4850	7640	10800	—	—	—	—
5	4370	5710	8560	12100	16900	19800	—	—
10	4870	6370	9590	13500	19000	22200	—	—
20	5730	7500	11800	16100	22600	26500	44500	—
30	6470	8460	13300	18300	25700	30200	51100	—
50	7720	10100	15900	22000	31000	36400	62100	78900
75	9040	11800	18600	25900	36600	43000	73600	93900
100	10200	13300	20900	29200	40700	48700	83600	107000
125	11200	14600	23000	32100	44800	53800	92400	119000
150	12100	15800	25000	34700	48400	58400	101000	129000
160	12400	16300	25600	35700	49800	60000	103000	132000

CFR SCREWED FILTER SCMH

INLET PRESSURE BARS	DIFFERENTIAL PRESSURE (LINE TAPS)									
	1 MB	2 MB	5 MB	10 MB	20 MB	50 MB	100 MB	150 MB	250 MB	350 MB
¾" NPT										
.5	9	14	22	31	44	69	96	116	145	164
1	11	16	25	36	51	80	113	136	171	197
2	14	19	31	44	63	99	139	169	215	249
3	16	23	36	51	72	115	162	197	250	292
4	18	25	40	57	81	129	181	221	282	330
5	19	28	44	63	89	141	199	242	310	364
10	27	38	60	85	121	191	270	330	424	499
1" NPT										
.5	11	16	26	37	52	81	114	137	170	193
1	13	19	30	42	60	94	133	160	201	231
2	16	23	37	52	74	117	164	199	252	293
3	19	27	42	60	85	135	190	231	294	344
4	21	30	47	67	95	151	213	259	331	388
5	23	33	52	74	105	166	233	285	364	427
10	31	45	71	101	142	225	317	388	498	587
1½" NPT										
.5	56	79	126	178	250	392	545	655	814	923
1	65	91	145	205	290	454	634	767	963	1110
2	79	113	178	252	355	559	784	952	1210	1400
3	91	130	206	291	411	647	909	1110	1410	1640
4	103	145	230	325	459	724	1020	1240	1590	1860
5	113	159	252	356	503	794	1120	1360	1740	2050
10	153	216	341	482	682	1080	1520	1860	2390	2810
2" NPT										
.5	72	103	162	229	323	505	702	844	1050	1190
1	83	119	187	285	373	586	818	988	1240	1430
2	103	145	230	324	458	720	1010	1230	1560	1810
3	119	168	265	375	529	834	1170	1430	1820	2120
4	133	188	296	419	592	933	1310	1600	2040	2390
5	145	205	325	459	649	1020	1440	1760	2250	2640
10	197	278	440	622	879	1390	1960	2390	3070	3620

1 Bar = 100 kPa 1 MB (Millibar) = 0.1 kPa

CAPACITY TABLES 0.6 SPECIFIC GRAVITY*

The differential pressure is taken from line taps shown in the drawing on page 5 and represents startup conditions only, using a new element.

CFR PILOT FILTER SCFH

INLET PRESSURE PSIG	DIFFERENTIAL PRESSURE							
	1" WC	2" WC	5" WC	10" WC	20" WC	1 PSI	3 PSI	5 PSI
¼" NPT								
.25	75	106	—	—	—	—	—	—
1	81	109	171	241	—	—	—	—
5	90	120	192	271	379	443	—	—
10	101	134	215	303	426	498	—	—
20	120	159	254	360	507	594	998	—
30	136	180	289	409	577	676	1150	—
50	164	217	347	493	695	817	1390	1770
75	193	255	409	578	820	964	1650	2110
100	218	288	463	654	925	1090	1870	2400
125	241	318	510	722	1020	1200	2070	2660
150	261	346	554	784	1110	1310	2250	2890
200	298	395	633	895	1270	1500	2580	3310
300	361	478	766	1080	1530	1810	3130	4030
500	462	611	980	1390	1960	2320	4010	5160
750	563	745	1190	1690	2390	2830	4890	6310
1000	649	858	2290	1950	2750	3260	5640	7270

CFR PILOT FILTER SCMH

INLET PRESSURE BARS	DIFFERENTIAL PRESSURE (LINE TAPS)										
	1 MB	2 MB	5 MB	10 MB	20 MB	50 MB	100 MB	150 MB	250 MB	350 MB	
¼" NPT											
.5	1	2	3	5	7	11	15	18	23	26	
1	1	2	4	5	8	13	18	22	27	31	
2	2	3	5	7	10	16	22	27	34	40	
3	2	3	5	8	11	18	26	31	40	47	
4	2	4	6	9	13	20	29	35	45	53	
5	3	4	7	10	14	22	32	39	50	59	
10	4	6	9	13	19	31	43	53	68	81	
15	5	7	11	16	23	37	52	64	83	98	
20	6	8	13	19	27	42	60	74	95	113	
25	6	9	15	21	30	47	67	82	107	126	
30	7	10	16	23	33	52	73	90	117	138	
40	8	11	18	26	38	60	84	104	134	159	
50	9	13	21	29	42	67	94	116	150	177	
60	10	14	23	32	46	73	104	127	164	194	
70	11	15	24	35	50	79	112	137	177	209	
80	11	16	26	37	53	84	120	146	189	223	
90	12	17	28	40	56	89	127	155	200	237	
100	13	18	29	42	59	94	134	164	211	250	

1 Bar = 100 kPa 1 MB (Millibar) = 0.1 kPa

DIMENSIONS

CFR FLANGED FILTERS

DIMENSIONS

Model	Fig. No.	A	B	C	D	E	Weight lbs.	ANSI Flange Series
CFR-2-175	1	13 3/8	3 5/8	14	17	7	48	150
CFR-3-175	1	18 3/8	4 1/8	15	22 1/2	7	52	150

Model	Fig. No.	A	B	C	D	E	Weight lbs.	ANSI Flange Series
CFR-4-175	2	15 3/4	5	18	20 3/4	10 3/4	180	150
CFR-6-175	2	26 1/2	6	18	32 1/2	10 3/4	225	150

Model	Fig. No.	A	B	C	D	E	Weight lbs.	ANSI Flange Series
CFR-2-275	2	13 3/4	3 1/2	16	17 1/4	8 5/8	80	150
CFR-3-275	2	18 1/2	4	16	22 1/2	8 5/8	85	150
CFR-4-275	2	15 3/4	5	18	20 3/4	10 3/4	180	150
CFR-6-275	2	26 1/2	6	18	32 1/2	10 3/4	225	150

Model	Fig. No.	A	B	C	D	E	Weight lbs.	ANSI Flange Series
CFR-2-720	3	14 1/4	22	16	36 1/4	8 5/8	160	300
CFR-3-720	3	19 1/4	23	16	42 1/4	8 5/8	209	300
CFR-4-720	3	16 1/2	27	20	43 3/8	10 3/4	365	300
CFR-6-720	3	27 3/8	30	20	57 3/8	10 3/4	402	300

Model	Fig. No.	A	B	C	D	E	Weight lbs.	ANSI Flange Series
CFR-2-1440	3	14 3/4	23	37 3/4	41 5/8	8 5/8	260	600
CFR-3-1440	3	19 3/4	23	17	42 3/4	8 5/8	363	600
CFR-4-1440	3	17 1/4	27	20	44 1/4	10 3/4	521	600
CFR-6-1440	3	28	30	20	58	10 3/4	735	600

WEIGHTS - Lbs.

	2'	3'	4'	6'
CFR-175	48	52	180	225
CFR-275	80	85	190	225
CFR-720	160	209	365	402
CFR-1440	260	363	521	735

CFR FLANGED FILTER CONSTRUCTION DESCRIPTION

Model	Vent	Drain	Base	Cover Type	Cover Lifting	Clearance For Element Removal
CFR-175						
2" 3"	3/4" NPT Plugged	3/4" NPT Plugged	Dome	Plate	Plate	9"
4" 6"	3/4" NPT Plugged	3/4" NPT Plugged	Plate	Plate	2 Handle	9"
CFR-275						
2" 3"	3/4" NPT Plugged	3/4" NPT Plugged	Plate	Plate	2 Handle	9"
4" 6"	3/4" NPT Plugged	3/4" NPT Plugged	Plate	Plate	2 Handle	9"
CFR-720						
2" 3"	3/4" NPT Plugged	3/4" NPT Plugged	Domed	Plate	Lever Lift	9"
4" 6"	3/4" NPT Plugged	3/4" NPT Plugged	Domed	Plate	Lever Lift	9"
CFR-1440						
2" 3"	3/4" NPT Plugged	3/4" NPT Plugged	Domed	Plate	Lever Lift	9"
4" 6"	3/4" NPT Plugged	3/4" NPT Plugged	Domed	Plate	Lever Lift	9"

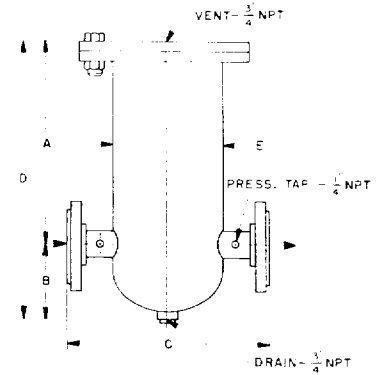

FIGURE 1

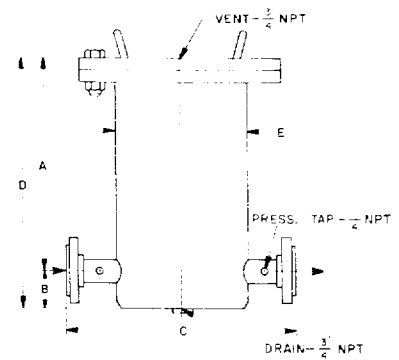

FIGURE 2

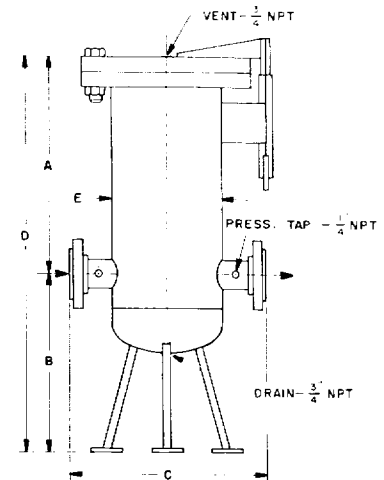
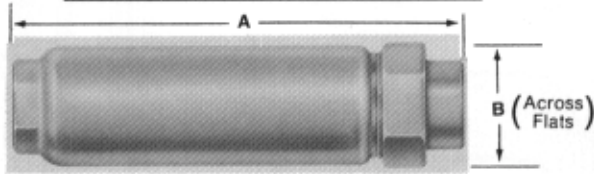

FIGURE 3

ORDERING INFORMATION

CFR SCREWED TYPE FILTER DIMENSIONS & WEIGHTS - Lbs.

Size	Lbs.	A	B
3/4	2	6"	1 15/16"
1	4	9"	2 5/16"
1 1/2	18 1/2	15"	3 7/8"
2	19	15"	3 7/8"



CFR PILOT FILTER DIMENSIONS & WEIGHTS - Oz.

Pipe Size	Oz.
1/4" NPT	15

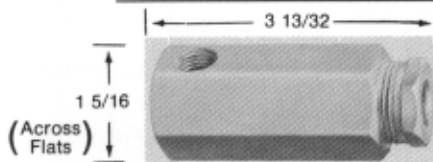

FILTER ELEMENT SPECIFICATION

CFR FLANGED FILTER

Size	Size of Element	Number Required	Part Number* 25 Micron	Part Number 10 Micron
2"	6" Dia. by 8 1/2"	1	78155P018	78155P017
3"	6" Dia. by 4"	1	78155P020	78155P019
3"	6" Dia. by 8 1/2"	1	78155P018	78155P017
4"	8" Dia. by 8 1/2"	1	78155P022	78155P021
6"	8" Dia. by 8 1/2"	2	78155P022	78155P021

*Standard

CFR SCREWED FILTER

Size	Size of Element	Number Required	Part Number 5 Micron
3/4"	1 1/4" x 3 5/8"	1	73355G001
1"	1 1/4" x 6 3/16"	1	73355G002
1 1/2"	2 1/2" x 11 5/32"	1	73355G004
2"	2 1/2" x 11 5/32"	1	73355G004

CFR PILOT FILTER

Size	Size of Element	Number Required	Part Number 5 Micron
1/4" NPT	11/16" x 1 3/4"	1	73408G001

REPLACEMENT PARTS CFR FLANGED FILTER

Model	End Cap & Spring Assembly	Center Seal	Cover O-Ring
CFR 175			
2"	78484G001	None Used	42710P164
3"	78484G001	78485G001	42710P164
4"	78484G002	None Used	42710P166
6"	78484G002	78485G002	42710P166
CFR 275			
2"	78484G001	None Used	42710P165
3"	78484G001	78485G001	42710P165
4"	78484G001	None Used	42710P166
6"	78484G002	78485G002	42710P166
CFR 720			
2"	78484G001	None Used	42710P165
3"	78484G001	78485G001	42710P165
4"	78484G002	None Used	42710P166
6"	78484G002	78485G002	42710P166
CFR 1440			
2"	78484G001	None Used	42710P165
3"	78484G002	78485G001	42710P165
4"	78484G002	None Used	42710P166
6"	78484G003	78485G002	42710P166

ORDERING INFORMATION

To order an American Meter CFR type filter, please specify:

1. Type of filter
2. Size of Filter
3. Working pressure
4. ANSI flange rating

TYPE	FLANGED	SCREWED	PILOT
Size	2,3,4,6,	3/4, 1, 1 1/2, 2	1/4
Max W.P.	175, 275, 720, 1440	160	1000
Element	25 micron*	5 micron	5 micron

* A 10 micron element may be ordered as a separate item.